

(3 Hours)

- (1) Question No. 1 is compulsory.
- (2) Solve any three questions from the remaining five
- (3) Figures to the right indicate full marks
- (4) Assume suitable data if necessary and mention the same in answer sheet.

[20]

Attempt any 5 questions

- a) Compare series and shunt regulator.
- b) What are the major limitation of class B power amplifier and how to overcome the same?
- c) What is the need of dual power supply biasing for differential amplifier?
- d) Which type of biasing technique is used to bias Integrated Circuit
- e) Draw and explain frequency response of BJT CE amplifier.
- f) Explain line regulation and load regulation of voltage regulator. Draw the line and load regulation characteristics of ideal and practical voltage regulator.

- a) For the circuit shown in Fig. 2a, the transistor parameters are $V_{BE(on)} = 0.7V$, $\beta=100$, $C_{\pi} = 2 \text{ pF}$, $C_{\mu} = 0.2 \text{ pF}$. Find lower cutoff frequency and midband gain. [10]

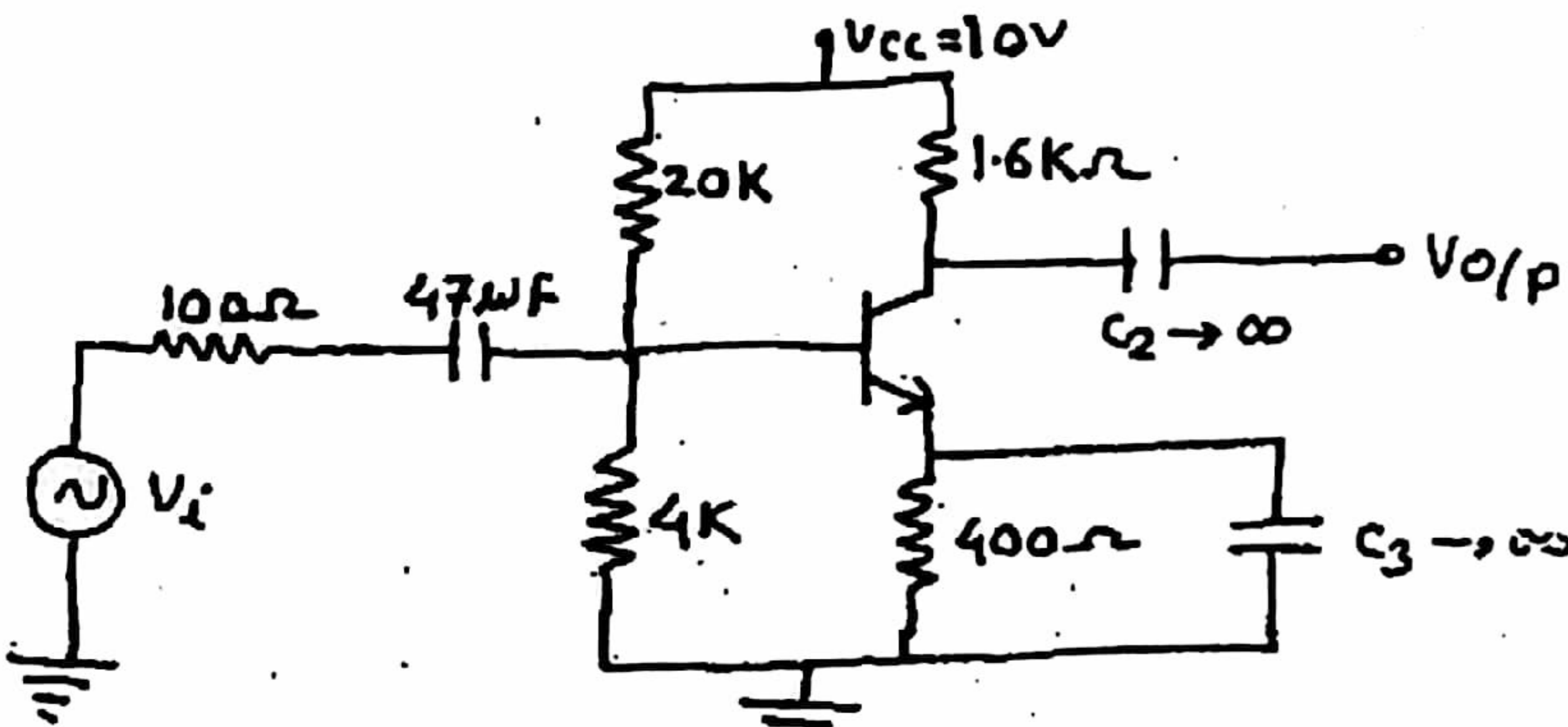

Fig.2a

- b) Determine unity gain bandwidth of N channel MOSFET with parameters $K_n = 0.25 \text{ mA/V}^2$, $V_{TN} = 1V$, $\lambda=0$, $C_{gd} = 0.04 \text{ pF}$, $C_{gs} = 0.2 \text{ pF}$, $V_{GS} = 3V$. If a $10 \text{ k}\Omega$ load is connected to the output between drain and source determine the Miller capacitance and cut-off frequency. [10]
- a) Draw circuit diagram of MOSFET based differential amplifier and derive the expression for differential gain, common mode gain and CMRR. [10]
- b) Determine overall input resistance and output resistance of the circuit as shown below in Fig. 3b. For both the transistors $\beta=120$ [10]

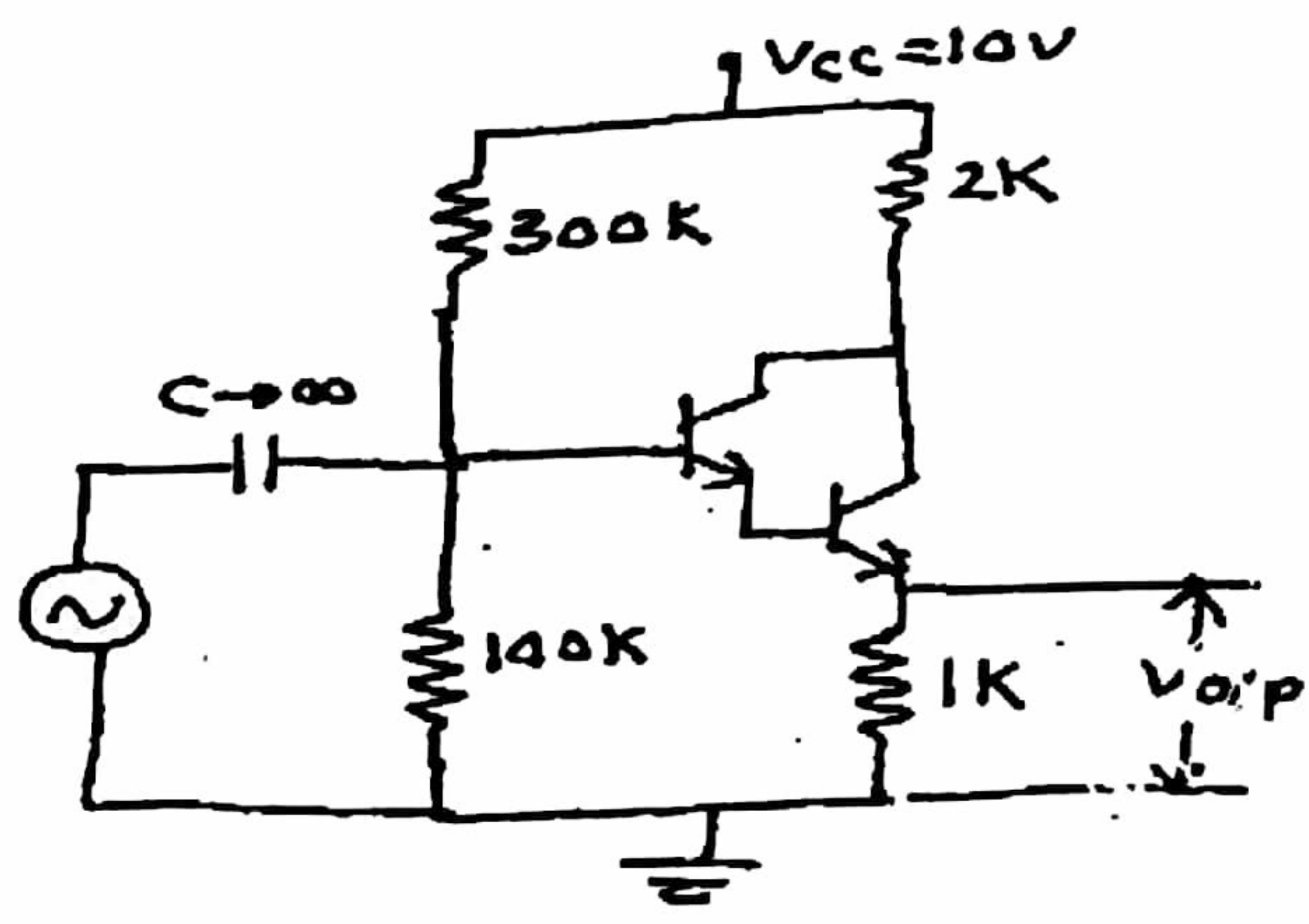

Fig. 3b

- Q.4
- a) Explain the working of two transistor (BJT) current source with the help of necessary current relationships. Also explain the effect of finite output resistance on current source performance and techniques to improve the same.
 - b) Draw the circuit of V_{BE} multiplier biased class AB amplifier and explain the working and advantages of V_{BE} multiplier biased class AB amplifier.
 - c) What are the ideal characteristics of opamp and also explain the effect of high frequency on OPAMP gain and phase.
- Q.5
- a) Draw the circuit diagram of transformer coupled class A power amplifier. Also draw ac and dc loadlines for the same. Derive the expression for its power conversion efficiency.
 - b) Explain the working of basic differentiator with the help of input and output waveforms. Also derive the expression for the output voltage. What are the limitations of basic differentiator and how to overcome these limitations.
- Q.6 Short notes on: (Attempt any four)
- a) Zener voltage regulator
 - b) Power MOSFET
 - c) Class AB power amplifier
 - d) High pass and Low pass filter using OPAMP
 - e) High Frequency hybrid pi model of BJT